

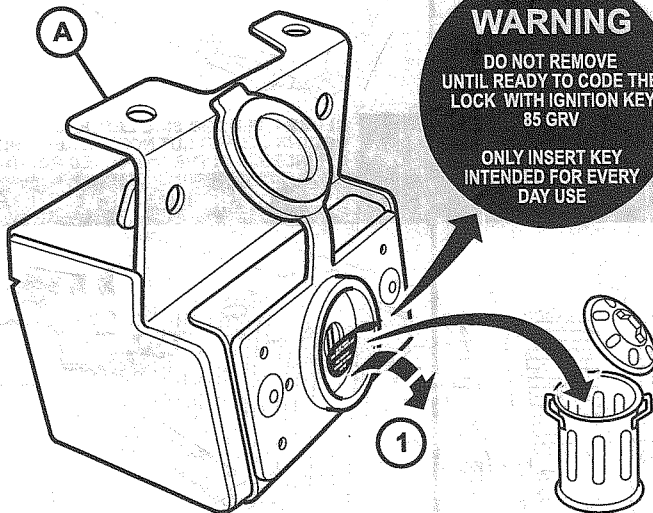

# JEEP WRANGLER

## Hood Lock Kit

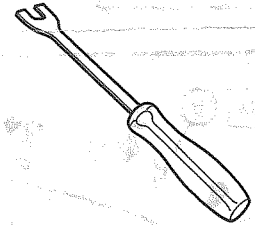
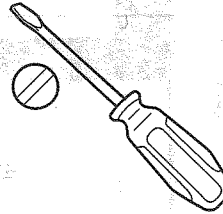
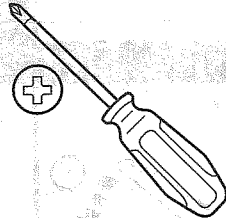
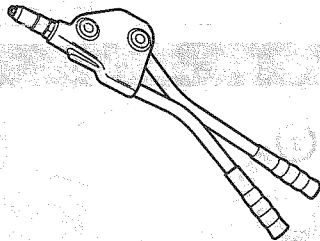
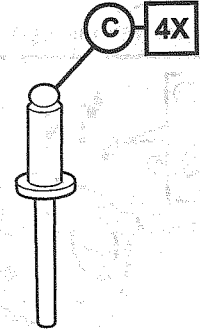
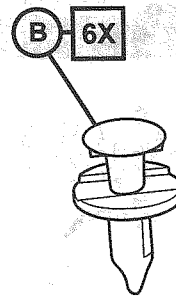
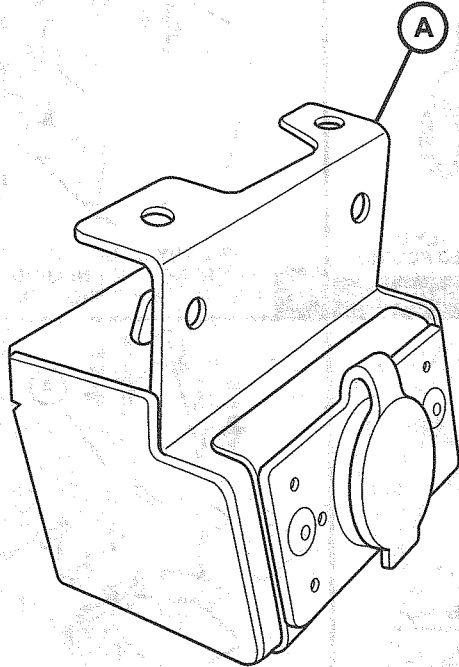

### WARNING

DO NOT REMOVE UNTIL READY TO CODE THE LOCK WITH IGNITION KEY 85 GRV

ONLY INSERT KEY INTENDED FOR EVERY DAY USE

**1** READ WARNING LABEL AND REMOVE IT.

### PROCEDURE TO CODE THE LOCK CYLINDER

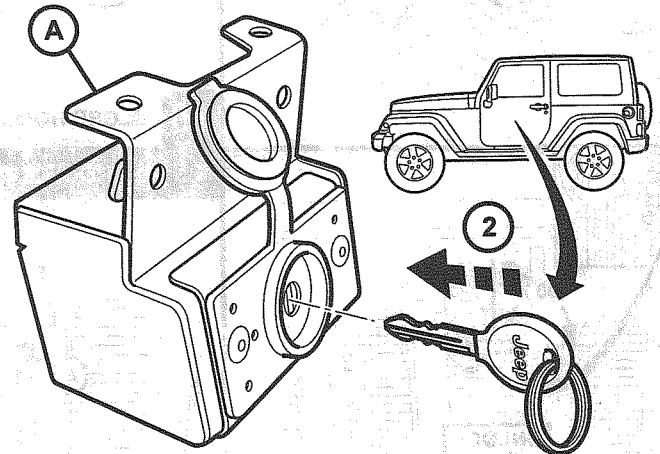

**2** FULLY INSERT THE IGNITION KEY.

**PROCEDURE TO CODE THE LOCK CYLINDER**

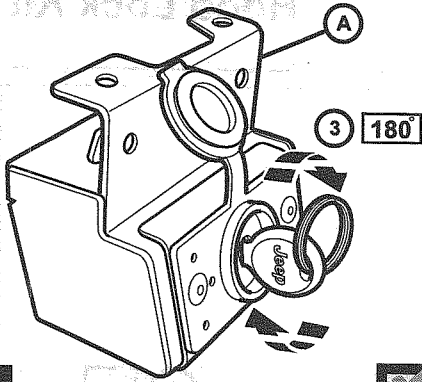

**3** TURN THE KEY 180° CLOCKWISE.

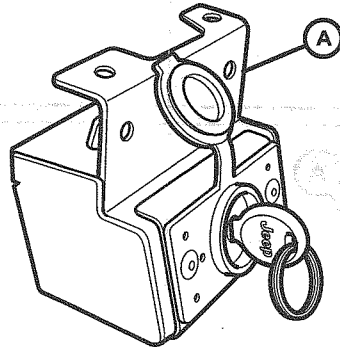

**4** LOCK IS NOW CODED TO YOUR IGNITION KEY

**CYCLE LOCK WITH KEY PRIOR TO RIVETING TO CROSSMEMBER TO ENSURE SUCCESSFUL CODING**

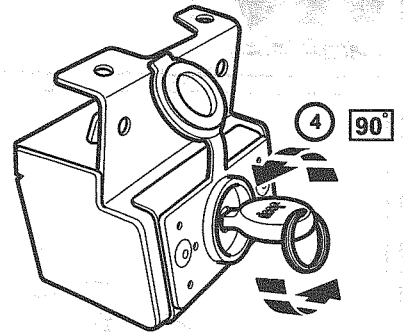

**5** TURN KEY COUNTER CLOCKWISE 90°. KEY IS NOW IN UNLOCKED POSITION AND CAN NOT BE REMOVED.

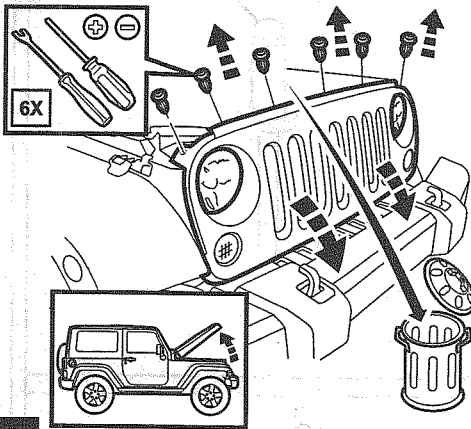

**6**

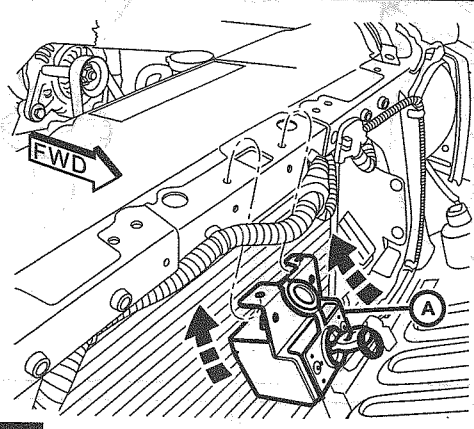

**7**

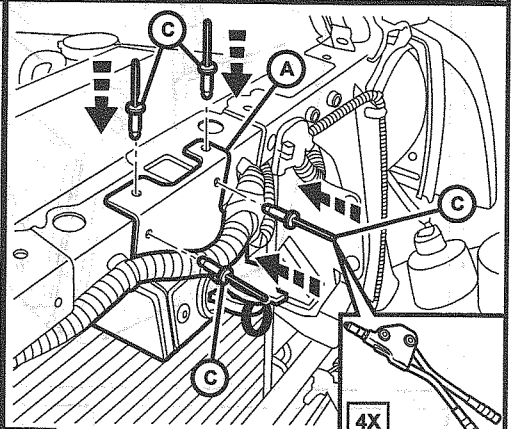

**8**

**PROCEDURE TO LOCK HOOD**

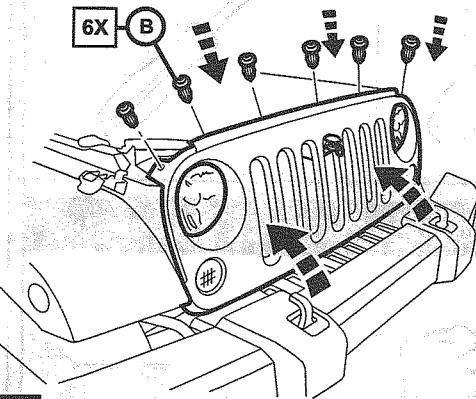

**9**

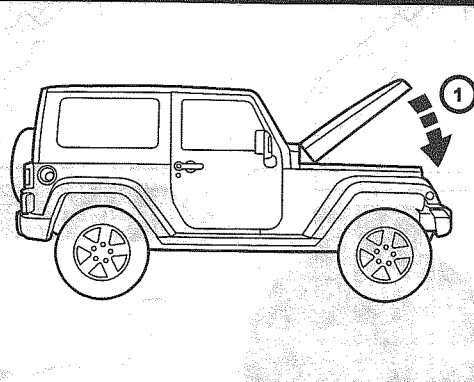

**10** CLOSE HOOD.

**PROCEDURE TO LOCK HOOD**

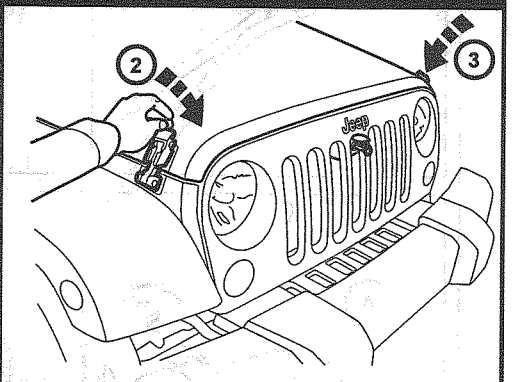

**11A** CLOSE THE HOOD SIDE LATCHES. HOOD IS CLOSED BUT NOT LOCKED. THE LOCK CYLINDER IS IN THE UNLOCKED POSITION.

**PROCEDURE TO LOCK HOOD**

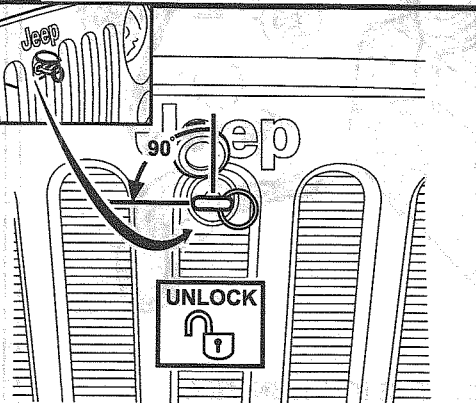

**11B** NOTE: KEY CAN NOT BE REMOVED IN THE HORIZONTAL CYLINDER POSITION.

**PROCEDURE TO LOCK HOOD**

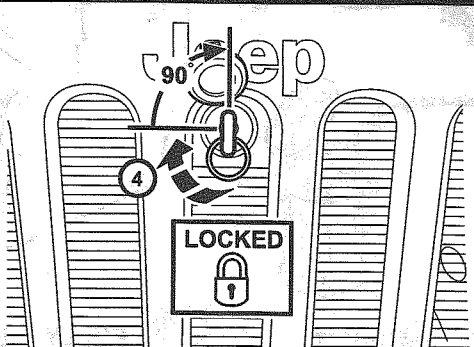

**12** TURN KEY CLOCKWISE 90° TO LOCK.

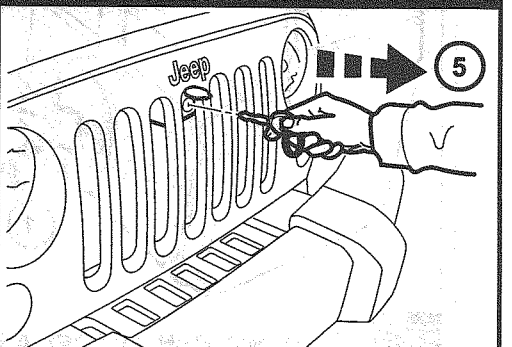

**13** HOOD IS NOW LOCKED. KEY CAN NOW BE REMOVED.