

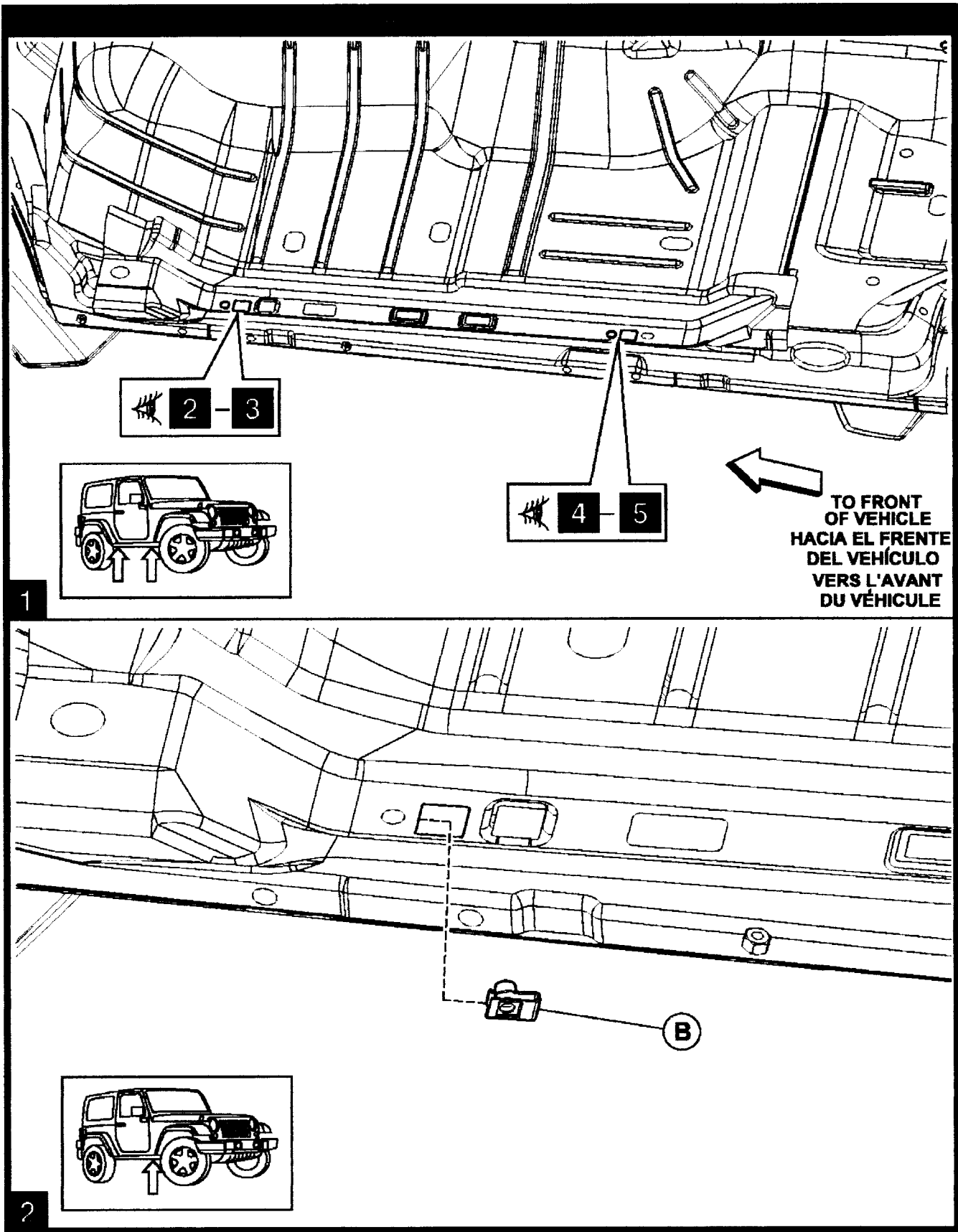

JEEP TWO DOOR WRANGLER

TUBULAR SIDE STEPS
ESTRIBOS LATERALES TUBULARES
MARCHEPIEDS TUBULAIRES

A 2X		B 2X		C 6X			
D 6X	E 4X	F 4X	G 8X				
H REAR PARTE TRASERA ARRIÈRE		PASSENGER'S SIDE LADO DEL PASAJERO CÔTÉ PASSAGER			FRONT PARTE DELANTERA AVANT		
A 2X		B 2X		C 6X			
D 6X	E 4X	F 4X	G 8X				
I FRONT PARTE DELANTERA AVANT		DRIVER'S SIDE LADO DEL CONDUCTOR CÔTÉ CONDUCTEUR			REAR PARTE TRASERA ARRIÈRE		
<p>PROBLEMS? QUESTIONS? PLEASE CALL:</p>		<p>PROBLEMAS? ¿PREGUNTAS? PÓNGASE EN CONTACTO CON:</p>			<p>DES PROBLÈMES ? DES QUESTION ? VEUILLEZ CONTACTER:</p>		
		<p>1-866-639-8896</p>			<p>FAX 1-515-299-4594</p>		
					<p>FAX</p>		



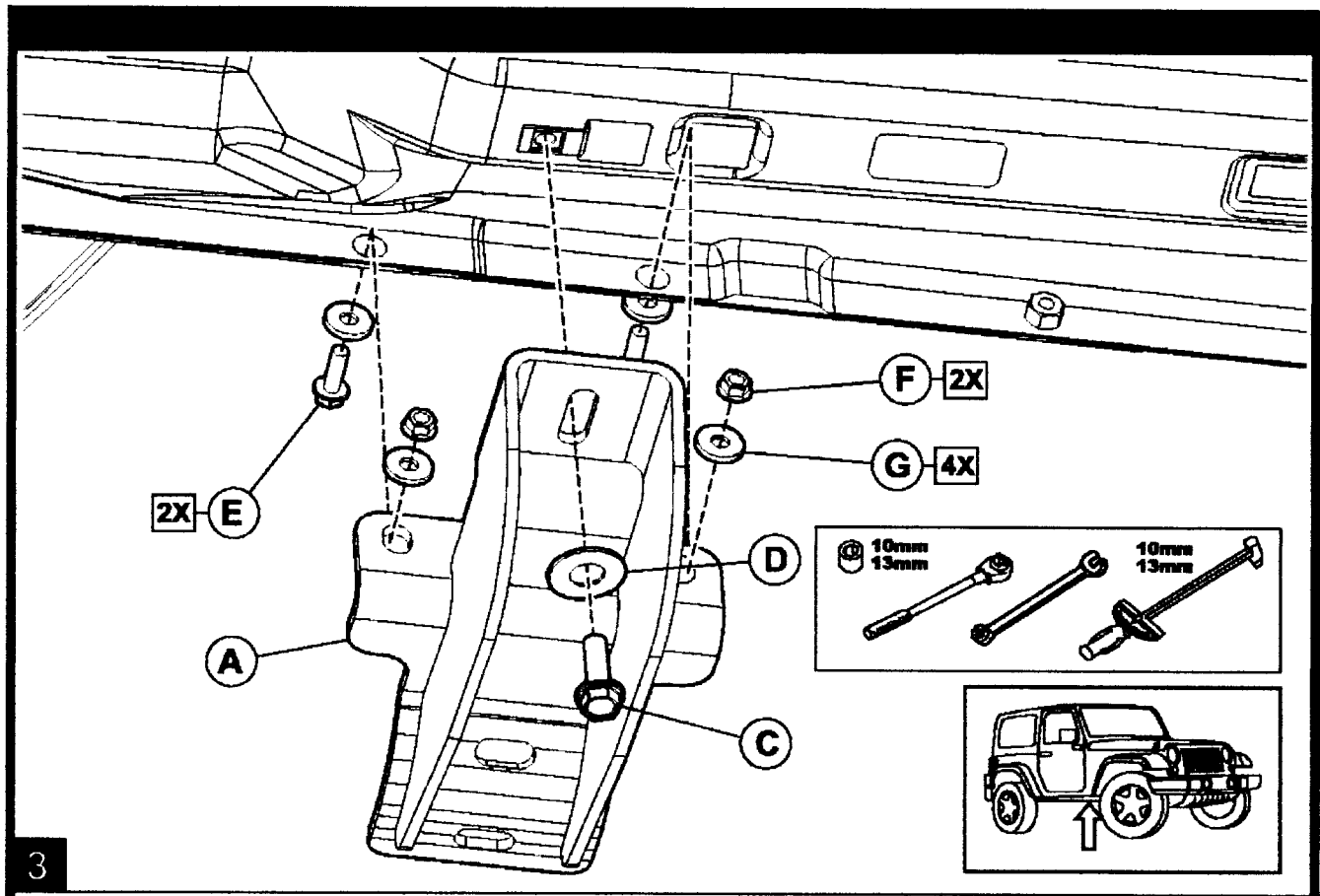

3

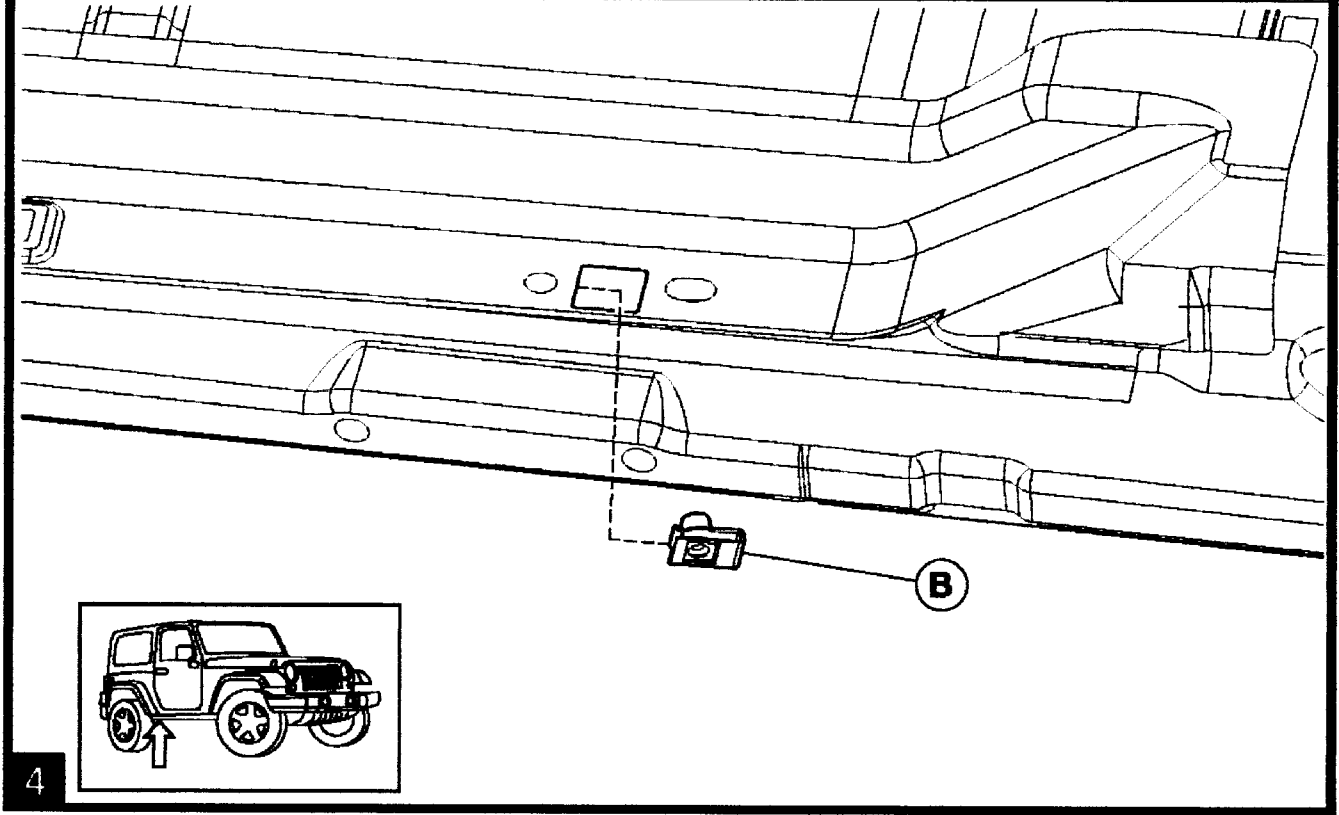

4

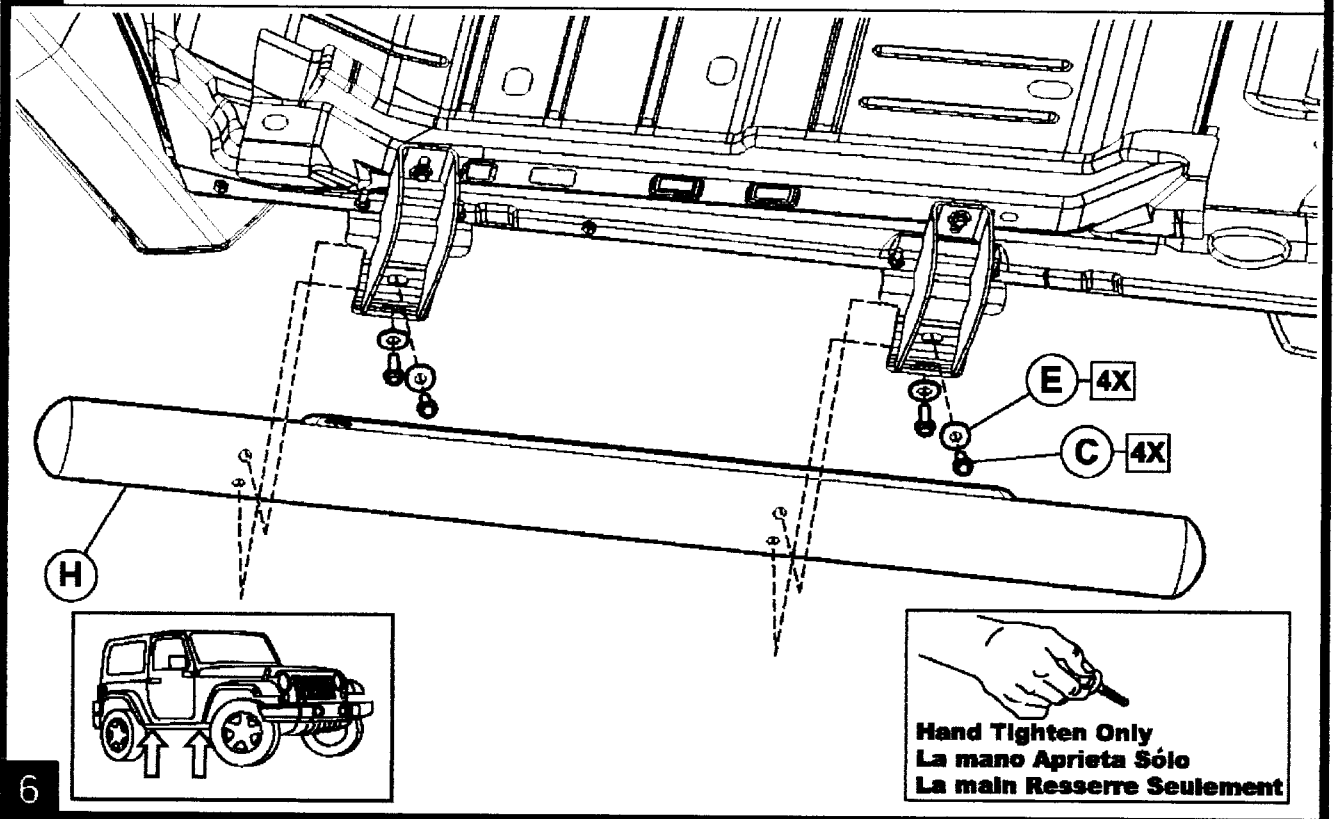
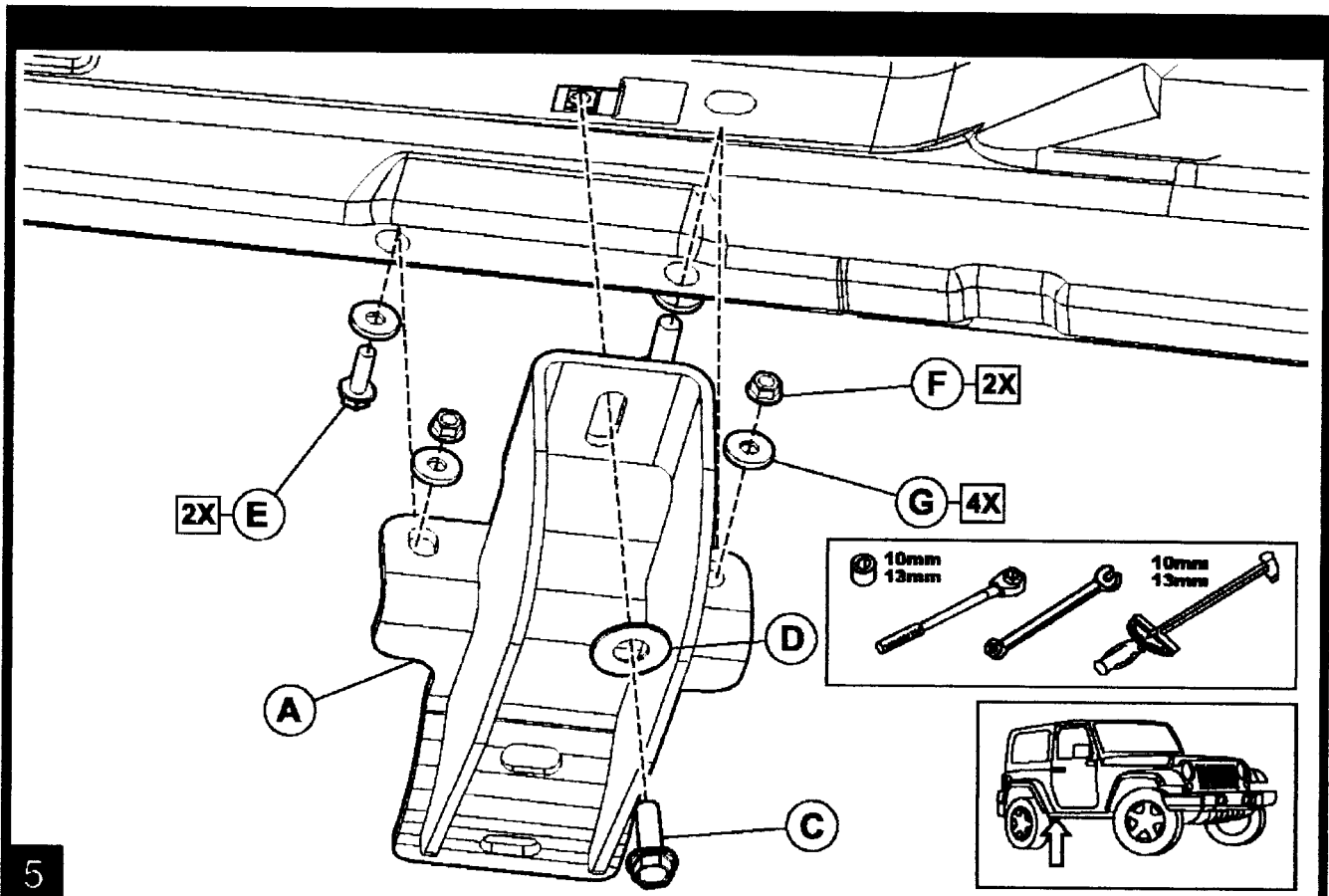

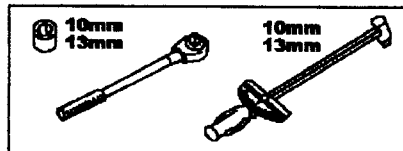
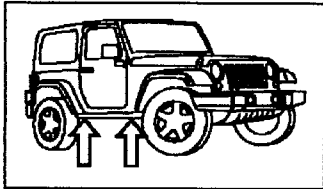
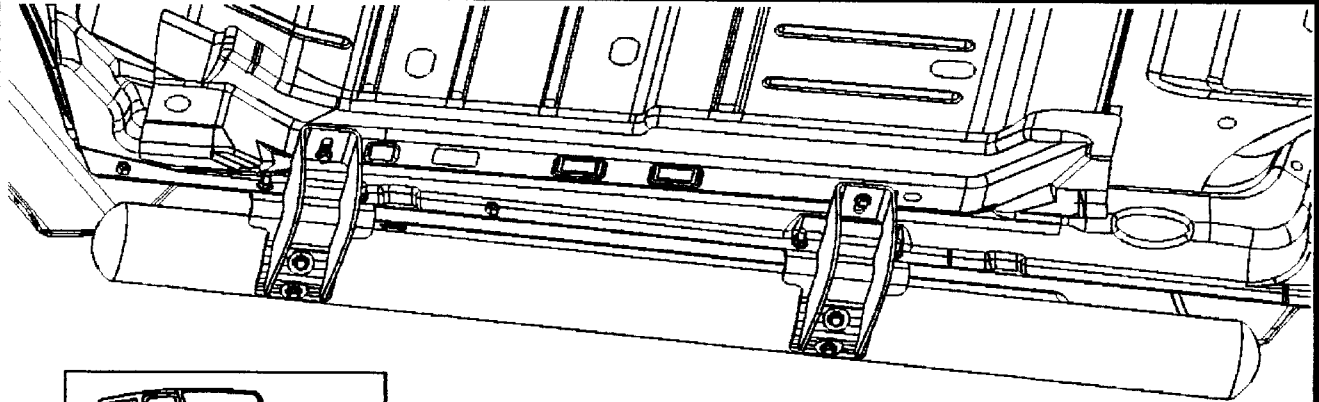

**TO FRONT
OF VEHICLE
HACIA EL FRENTE
DEL VEHÍCULO
VERS L'AVANT
DU VÉHICULE**

Tighten fasteners labeled "D" to 16 ft-lbs. (22 N-m). Tighten fasteners labeled "F" to 13 ft-lbs. (17 N-m). Repeat for driver's side.

CAUTION - Do Not Overtorque

Apriete los tornillos con la marca "D" a 16 pies-libras. (22N-m). Apriete los tornillos con la marca "F" a 13 pies-libras. (17 N-m).

Repita el procedimiento en el lado del conductor.

Precaución: No apriete demasiado

Resserrez les attaches "D" jusqu'à 16 ft-lbs. (22 N-m). Resserrez les attaches "F" jusqu'à 13 ft-lbs. (17 N-m). Répétez l'opération du côté conducteur.

7

Attention: Ne pas surcoupler