

READ ENTIRE INSTRUCTIONS THOROUGHLY BEFORE BEGINING INSTALLATION. FOLLOW PROCEDURES IN THE SERVICE MANUAL IF BUMPER NEEDS TO BE REMOVED.

NOTE: THIS HOOK IS TO BE USED ONLY WITH APPROVED MOPAR TRAILER TOW HITCH RECEIVERS. *

*** IN MOST CASES, A CLASS IV RECEIVER IS REQUIRED ON THE VEHICLE.**

TOOLS REQUIRED:

- 3/4" socket
- Power drill
- 17/32" metal drill bit

CONTENTS:

No.	Qty.	Description
1	1	Hook - Rear Tow
2	2	Hex Flange Bolt (1/2-13 x 1-1/2)
3	2	Handle Nut (1/2-13)
4	1	Installation Instructions

VEHICLE	FIGURE 1	FIGURE 2	RIGHT SIDE OF VEHICLE	LEFT SIDE OF VEHICLE
Grand Cherokee	NO	YES	YES	YES
Ram (full size)	YES	YES	YES	NO
Durango	NO	YES	YES	NO
Full size van	NO	YES	YES	YES
Dakota	YES	YES	YES	NO
Cherokee	YES	YES	YES	NO
Wrangler	YES	YES	YES	YES

NOTE: TO OBTAIN MAXIMUM STRENGTH USE EXTREME LEFT OR RIGHT SIDE OF RECEIVER CROSS TUBE, SUCH THAT THE HOOK IS POSITIONED AS CLOSE TO THE BRACKET THAT ATTACHES TO THE VEHICLE FRAME OR BODY.

- 1.) Refer to the chart above to choose the available mounting location on the vehicle. In some cases it may require removing the rear bumper. Never install the hook such that it is positioned behind or below the fuel tank.
- 2.) Clamp the tow hook (item 1) to cross tube. Use the hook as a template for the drilled holes by making marks on the cross tube. Then remove the hook from the cross tube.
- 3.) Drill (2) 17/32 holes in the hitch cross tube per vehicle cross reference chart location or customer's preference.

NOTE: CLEAN BARE EDGES OF THE DRILLED HOLES. APPLY MOPAR RUST INHIBITOR 82300508 (BRUSH TYPE) OR 82300068 (SPRAY TYPE). ALLOW TIME TO DRY.

- 4.) Bend handle nuts (item 3) as shown in the illustration below.
- 5.) Insert handle nuts (item 3) into the inside of hitch cross tube.
- 6.) Align holes in handle nut (item 3) with holes in hitch cross tube and tow hook (item 1).
- 7.) Fasten with two hex flange bolts (item 2).
- 8.) Tighten all 1/2" bolts to 75 ft/lbs. torque. If needed, snip off or bend handle nut into hitch cross tube.

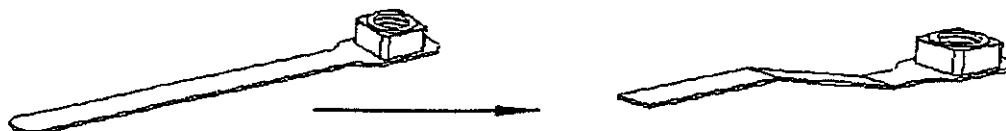

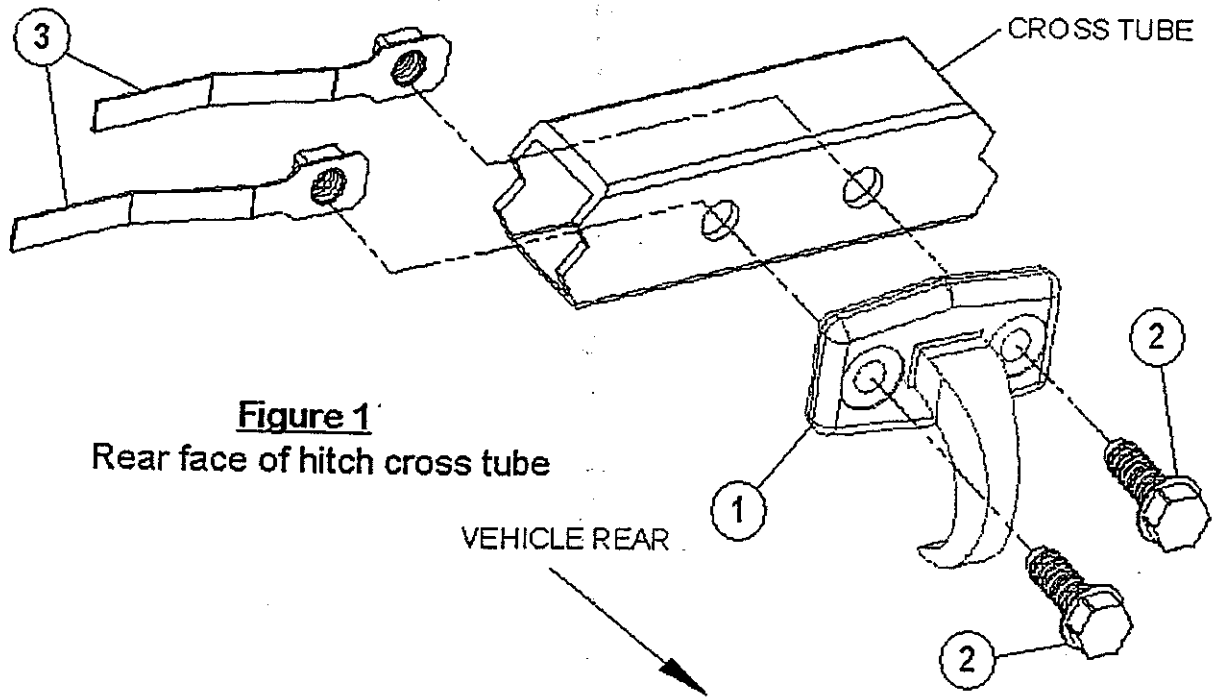

Figure 1
Rear face of hitch cross tube

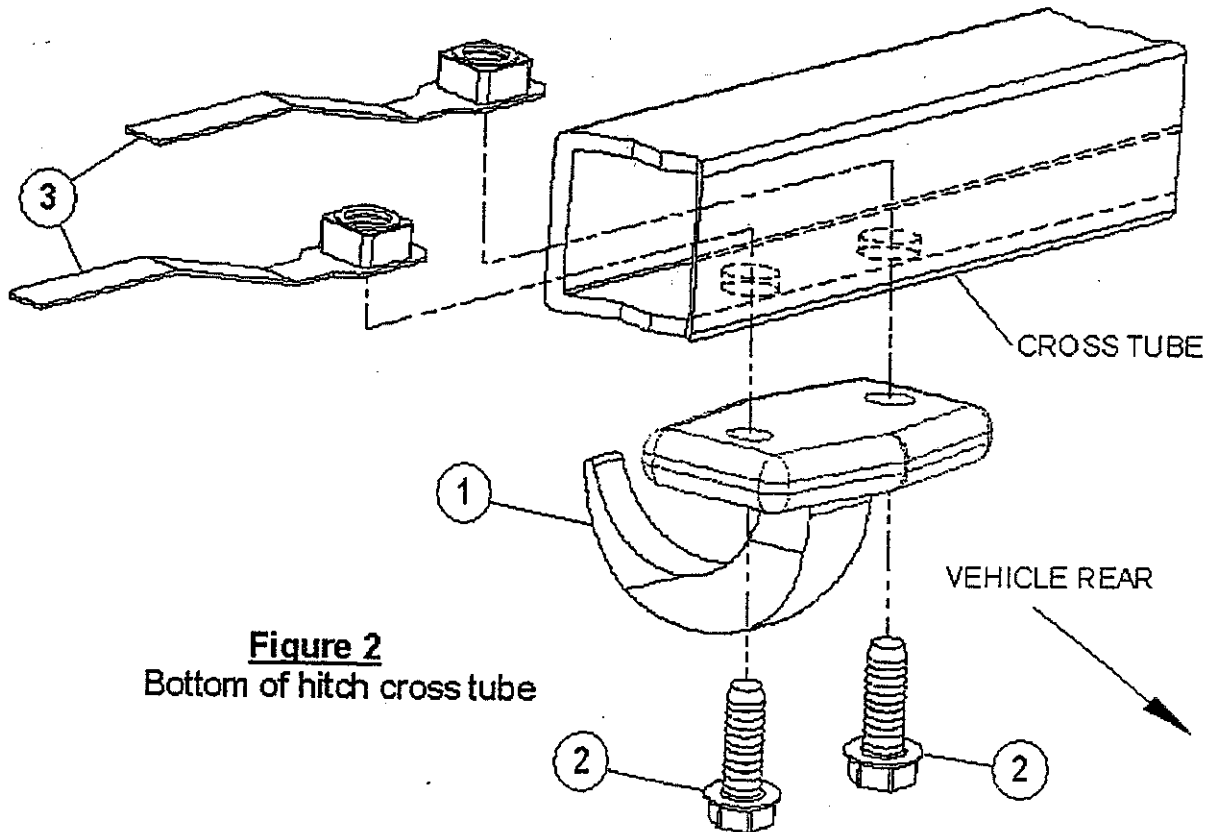

Figure 2
Bottom of hitch cross tube