

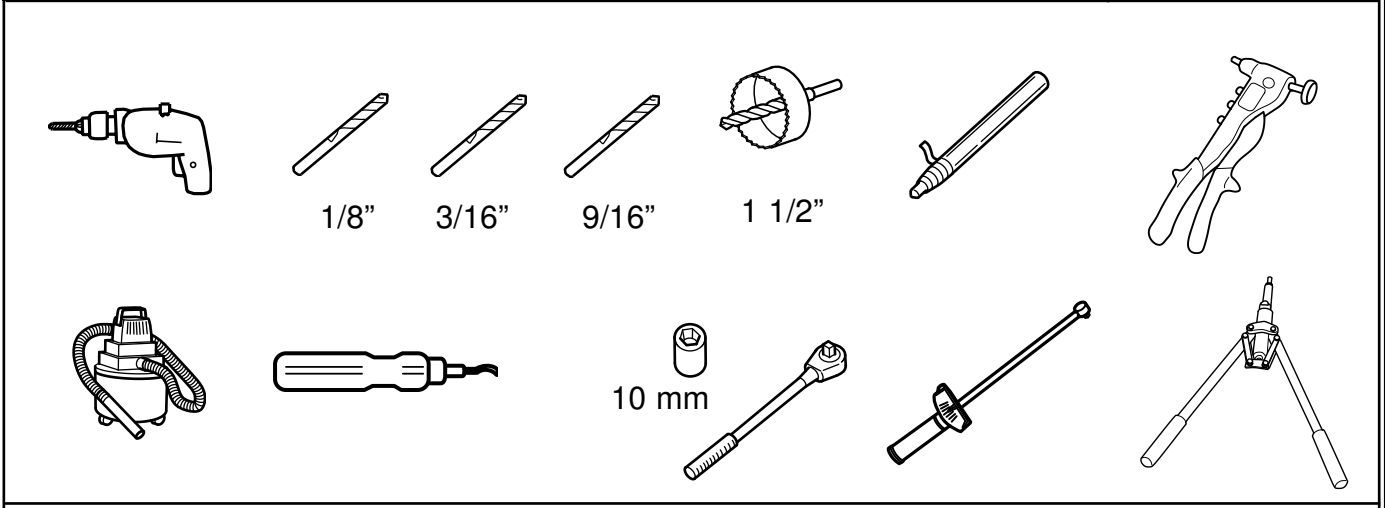

Lamp Bracket Kit COMPASS & PATRIOT

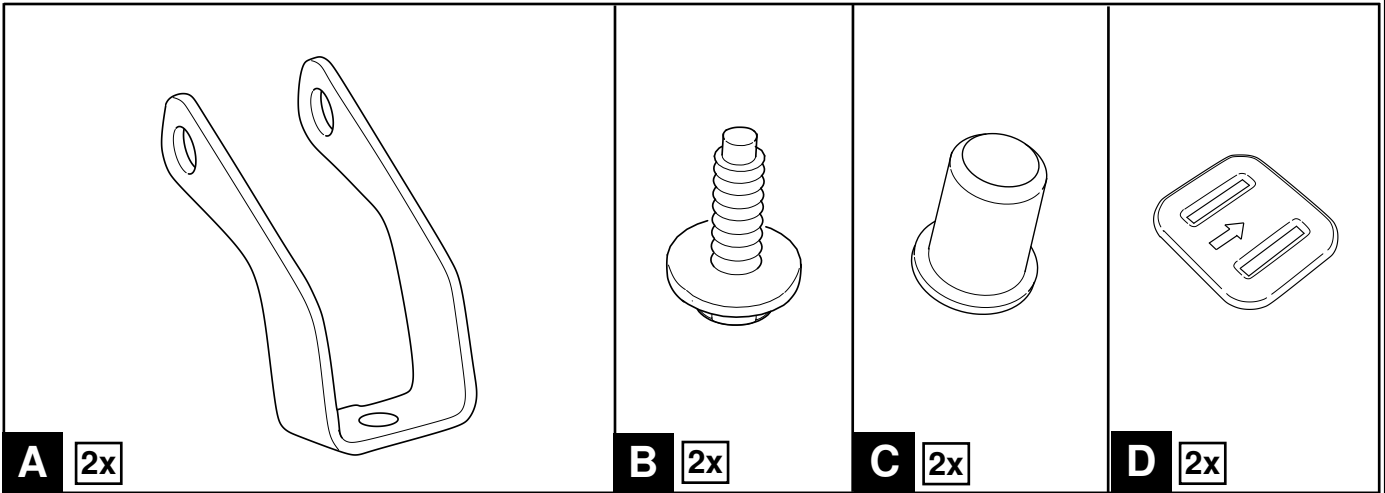

Repeat on other side
COMPASS MODEL SHOWN

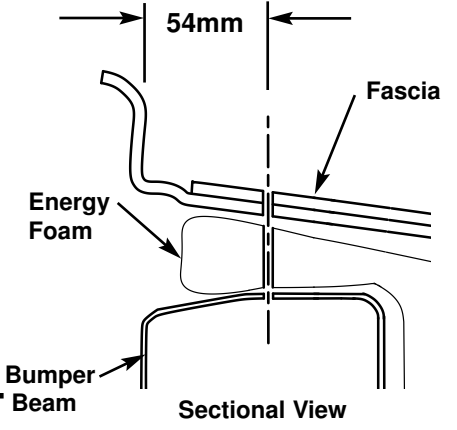
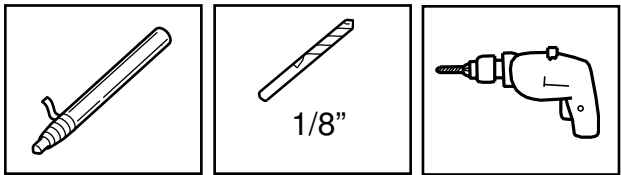
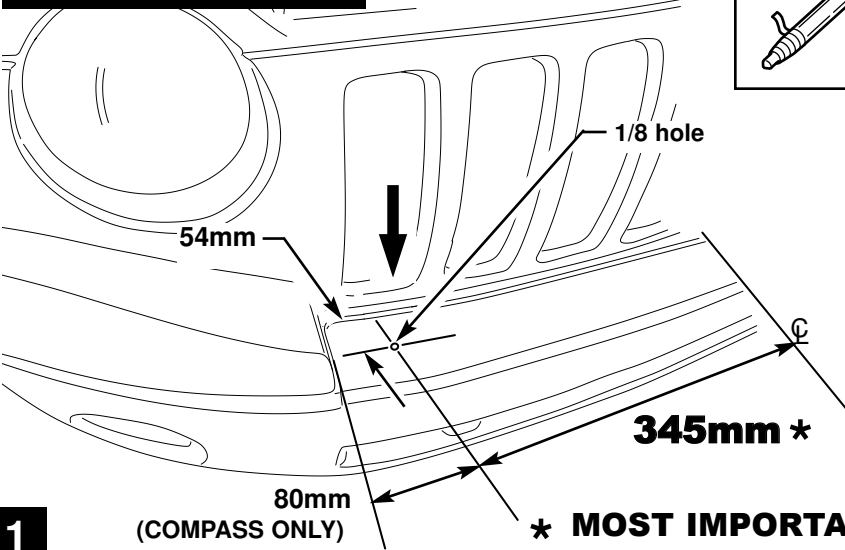

1

Repeat on other side

COMPASS MODEL SHOWN

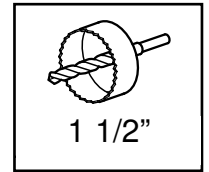
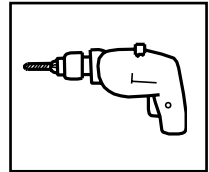
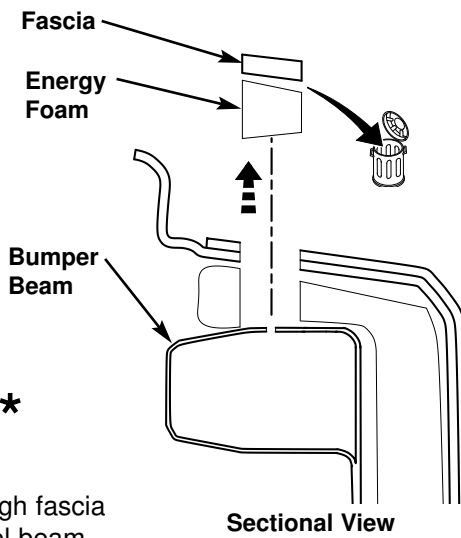
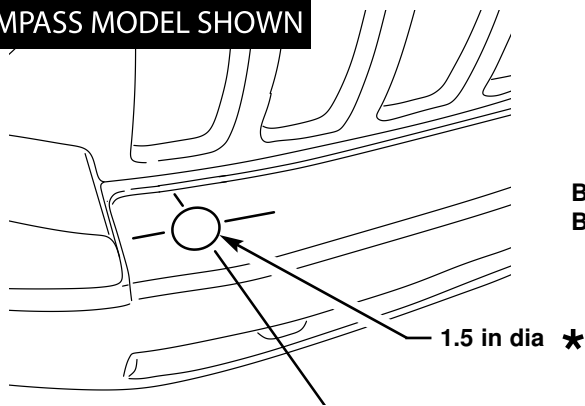

2

* When using the Hole Saw, only drill through fascia and energy foam. Do not drill through steel beam.

Repeat on other side

COMPASS MODEL SHOWN

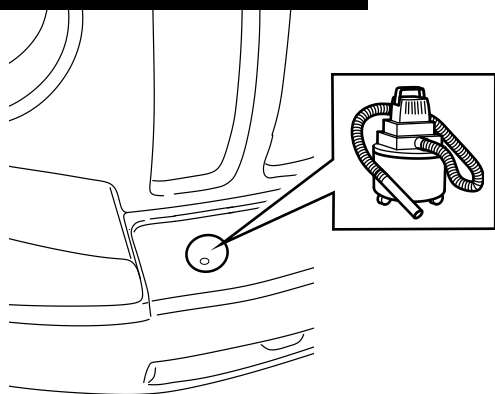

Repeat on other side

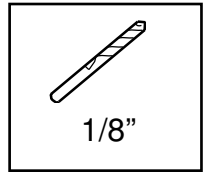
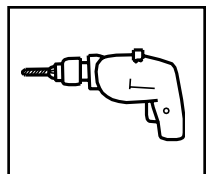
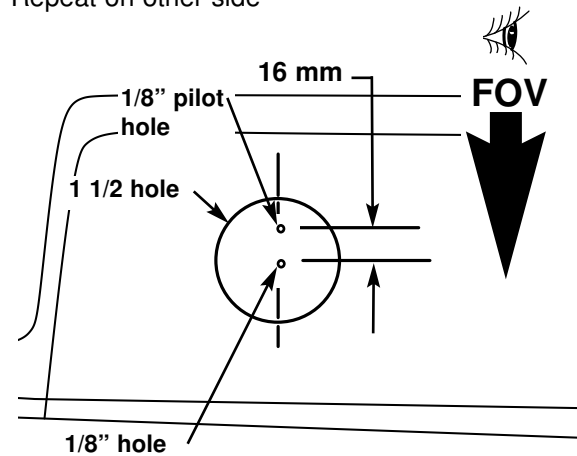

3

4

Repeat on other side

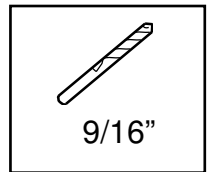
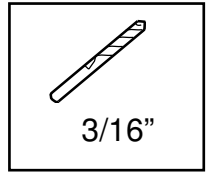
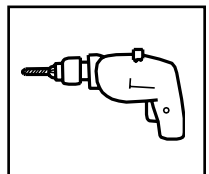
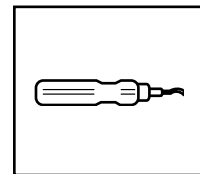
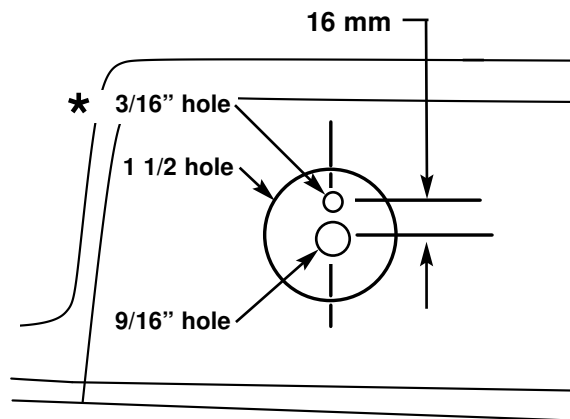

5

* The 3/16" hole **MUST** be drilled directly behind the 9/16" hole to insure lamps are aligned properly.

Repeat on other side

COMPASS MODEL SHOWN

B 20 N-m / 15 ft. lbs.

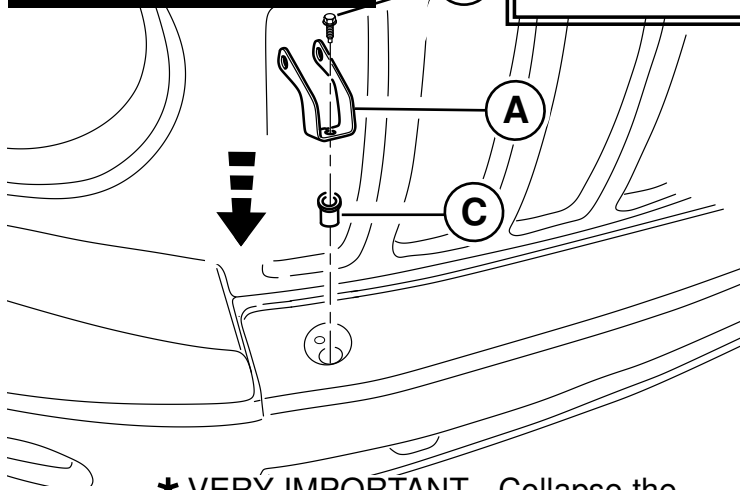
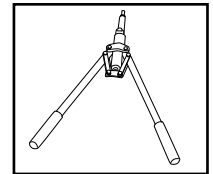
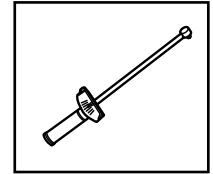
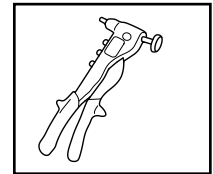
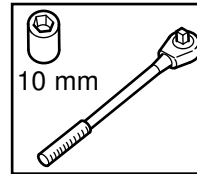

*** VERY IMPORTANT** - Collapse the rivnut carefully using a commercial grade rivnut setting tool.

6

Repeat on other side

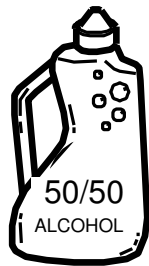

Clean fascia with soap and water then prep fascia with 50/50 alcohol mix.

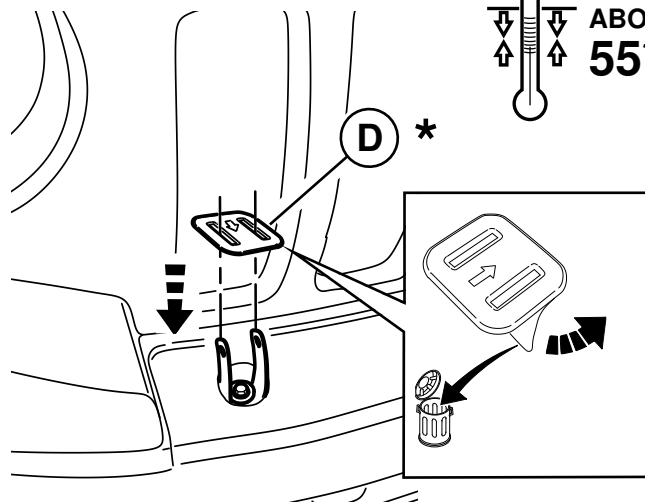

*** Remove adhesive protective film.**

7

Repeat on other side

5 lbs pressure



Hold in place for 30 seconds

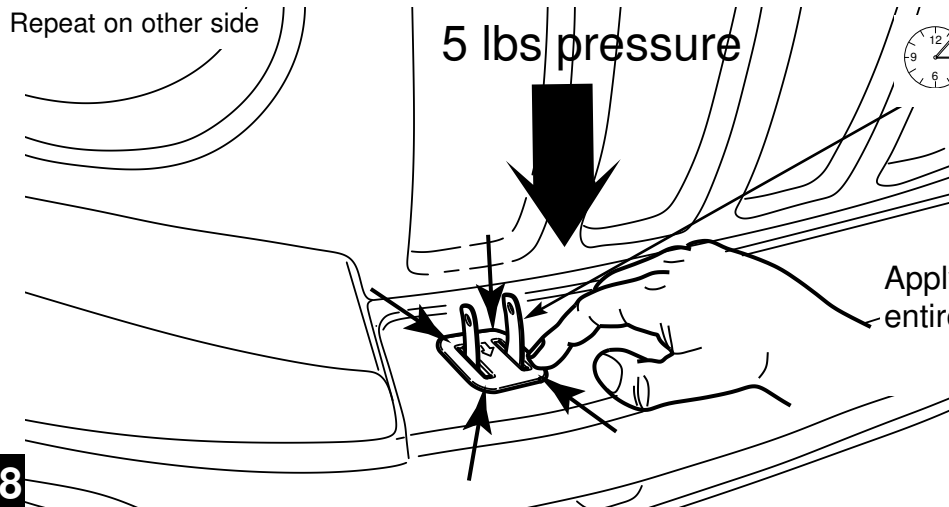

Apply uniform pressure around entire periphery of the Bezel to maximize adhesion.

8